

Rebuild Instructions

500 Series Metering Valve Vernier Micrometer

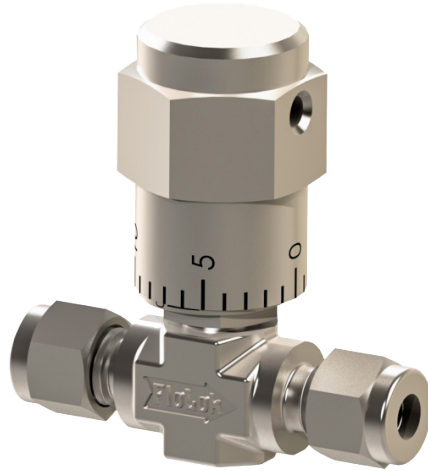

Packing Rebuild Kit Components:

Micrometer Handle	Handle Set Screw 10-32 X 1/4" length (3/32" Hex)	Micrometer Pack- ing Nut	Micrometer Barrel
Barrel Set Screw 8/32 x 1/8" length (5/64" Hex)	Micrometer Sleeve	Sleeve Set Screw 10-32 x 1/8" length (3/32" Hex)	

Disassembly

1. Remove the handle by loosening the set screw using a 3/32" Allen wrench.

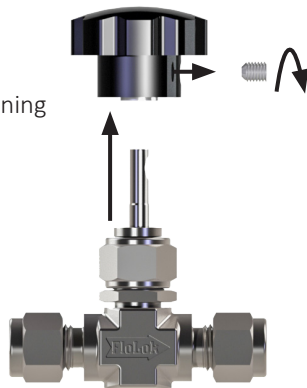

2. Use a wrench to remove the packing nut. (Make sure the packing springs are removed inside the packing nut.)

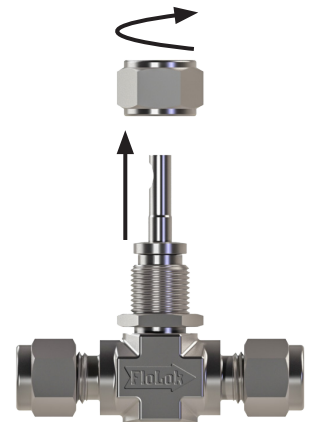

3. Place the micrometer barrel over the body threads resting on top of the panel nut.

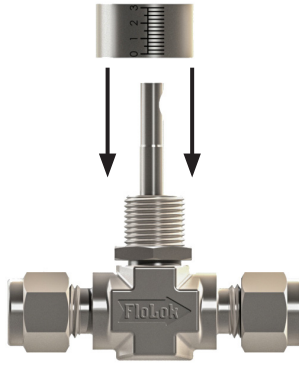

Assembly

4. Place the micrometer packing nut over the stem by using a torque wrench to tighten the nut onto the body. (See torque chart.)

Packing Nut	316SS		Brass	
	Min	Max	Min	Max
5/8" Hex	2.5 ft-lb	4 ft-lb	2.5 ft-lb	4 ft-lb
7/8 Hex	10 ft-lb	12 ft-lb	2.5 ft-lb	4 ft-lb

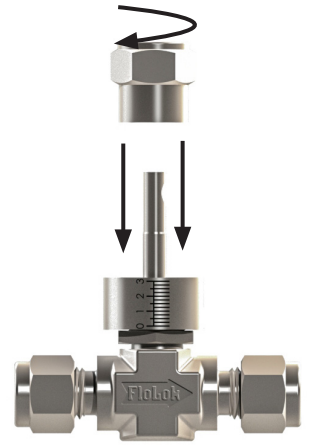

5. Place the sleeve over the stem. Use the 10-32 x 1/8" long set screw. Align the set screw hole in the sleeve with the drill point on the stem. Use a 3/32" Allen wrench to tighten the set screw until "snug" to secure the sleeve.

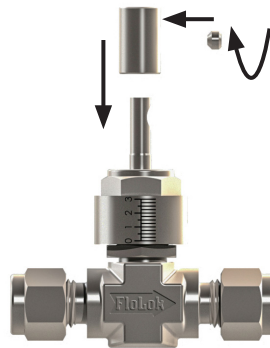

6. Place the handle over the sleeve. Use the 10-32 x 1/4" long set screw. Use a 3/32" Allen wrench to tighten the set screw until "snug" to secure the handle.



7. Turn the handle clockwise until the valve is closed. Keep the valve in the closed position until after installation is complete.



8. Move the micrometer barrel up under the handle so that the "zero" mark aligns with the bottom edge of the handle as shown. (The barrel may also be rotated to a position where measurements will be read from.) Then rotate the panel nut up against the barrel to temporarily hold it in place.

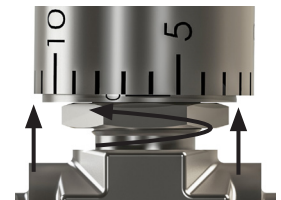

9. Remove the handle and set screw. Use a 5/64" allen wrench to tighten the 8-32 x 1/8" barrel set screw into the threaded hole in the barrel. Tighten the barrel set screw until "snug." The barrel is now secured to the packing nut.

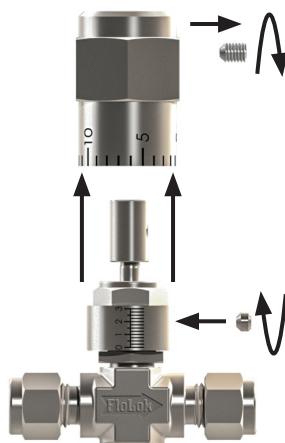

10. Place the handle on the stem so that the "zero" mark on the handle aligns with the "zero" mark on the barrel. Carefully tighten the set screw into the handle without losing the "zero" alignment.

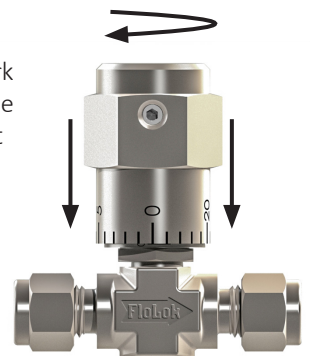

11. Installation is now complete. The valve will measure 0.0" when closed.