

SSP

Plug Valves



FloLok® PV Series

- ✓ Working Pressure: Up to 3,000 psig (200 bar)
- ✓ End Connections: 1/8 to 1/2 in. (6 to 12mm)
- ✓ Temperature Range: -10 to 400°F (-23 to 204°C)
- ✓ Wide variety of end connection types and sizes
- ✓ Flow Coefficient: Up to 6.4

www.mySSPusa.com





At SSP, we are proud to be an American manufacturing success story.

100% of our products are made in America. All of our manufacturing is performed in our 165,000 sq. ft. facility located near Cleveland, Ohio. Our facility is the largest vertically integrated, single-site operation in the industry. In addition to manufacturing and assembly, we have closed die forging, tool & die design, product engineering and testing operations under the same roof with customer service and management.

Made in America is good business. Not only do we make everything in America, we use American suppliers too. Buying American allows us to have better quality control and a more reliable supply chain. We can work more closely within our walls and with our suppliers to improve quality, reduce costs, and shorten lead times, which means faster service and better products for you.

Support where it counts. SSP products and services are supported by more than 4000 people and 350 distributor locations around the globe. For a distributor near you, contact SSP Customer Service or visit www.mySSPusa.com/distributors.

SSP Industry Standard Products
Made Better

Table of Contents

PV Series Plug Valves Introduction	3	Part Numbers and Dimensions Table.....	5
Features	3	Options	6
Materials of Construction	4	Special Order Instructions	7
Temperature and Pressure Ratings	4	Testing, Safety, Warranty	7
Ordering Information	4		

PV Series Plug Valves

PV Series quarter-turn plug valves are used for isolation and flow control in a wide range of applications including: gas supply manifolds, air systems, lube system controls, laboratories, instrument gas systems.

Design

- 1 1/4-TURN ACTUATION**
 - 1/4-turn, low-torque actuation
 - Directional handle indicates the direction of the flow
- 2 PTFE-COATED PLUG**
 - Reduces potential for galling
 - Low maintenance
- 3 PTFE-COATED O-RING SEAL TO ATMOSPHERE**
 - Choice of O-ring materials
 - Easy maintenance
- 4 ONE-PIECE BODY**
 - Compact size for tight spaces and close mounting
 - Lightweight
 - Fewer leak points

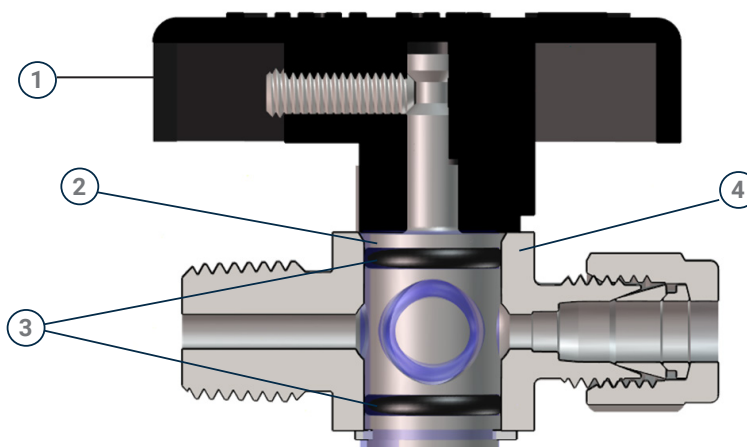

STRAIGHT FLOW PATH

- Forward-flow throttling
- High flow

VARIETY OF END CONNECTIONS

- Fractional Duolok®, Unilok® and Griplok® tube ends
- Metric Duolok® tube ends
- TruFit® NPT and ISO/BSPT pipe ends

100% FACTORY TESTED

Technical Information

Materials of Construction

ID	Component	316 SS	Brass
1	Handle	Nylon	
2	Set Screw	316 SS	
3	Plug*	316 SS/A479	Brass/B453
4	O-rings*	PTFE_Coated Fluorocarbon FKM	
5	Pin	420 SS	
6	Body*	316 SS/A479	Brass/B453
7	Snap Ring	PH 15-7 SS	
	Lubricant	Silicone-based	

*Wetted Components

Temperature - Pressure

Series	PV4, PV6	PV4	PV6
Material	316 SS	Brass	
Temperature °F (°C)	Working Pressure, psig (bar) ^{1, 2}		
-10 to 100 (-23 to 37)	3000 (206)	3000 (206)	2000 (137)
150 (65)	3000 (206)	2500 (172)	2000 (137)
200 (93)	3000 (206)	2000 (137)	2000 (137)
250 (121)	2000 (137)	1500 (103)	1500 (103)
300 (148)	1000 (68.9)	1000 (68.9)	1000 (68.9)
350 (176)	1000 (68.9)	1000 (68.9)	1000 (68.9)
400 (204)	1000 (68.9)	400 (27.5)	400 (27.5)

¹Based on FKM O-rings.

²Differential pressure is limited to 150 psig (10.3 bar) maximum if reverse flow occurs. Reverse-flow throttling may damage O-ring.

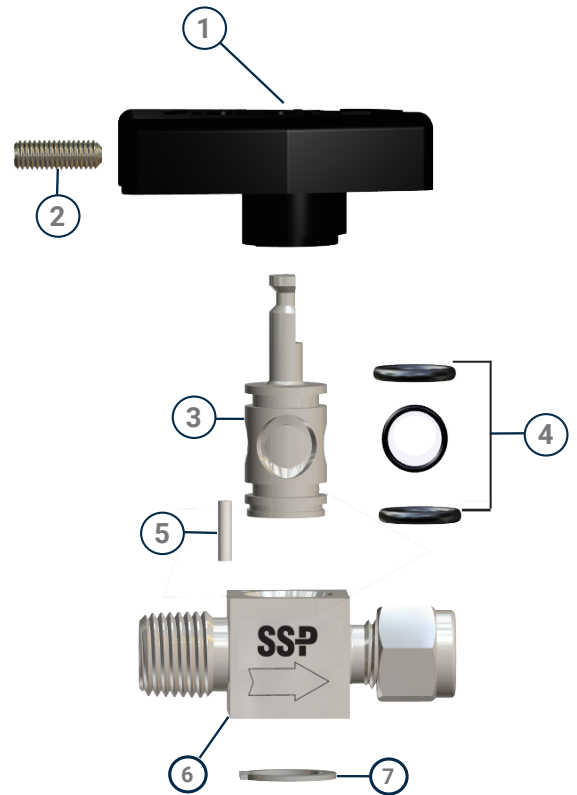

Ordering Information

Ordering Instructions

- ① Select the basic ordering number from the Part Numbers and Dimensions table based on the end connections and orifice size for the valve. **Example: PV4-4PM-D4**

Basic part numbers for valves with tube fitting end connections specify the Duolok two-ferrule design. To order Unilok single ferrule tube ends change the D to a U. **Example: PV4-4PM-U4**

To order Griplok dual-ferrule tube ends change the D to a G. **Example: PV4-4PM-G4**
- ② If the valve requires downstream venting to atmosphere, add a V to the base part number. **Example: PV4V-4PM-D4**
- ③ Select the body material, then add it to the base part number. **Example: PV4-4PM-D4-316**
- ④ Add Options and Accessories to the end of the part number in alphabetical order. See the Options and Accessories section for more information. **Example: PV4-4PM-D4-316-LD**

Part Numbers and Dimensions

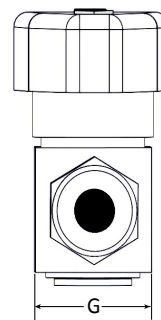
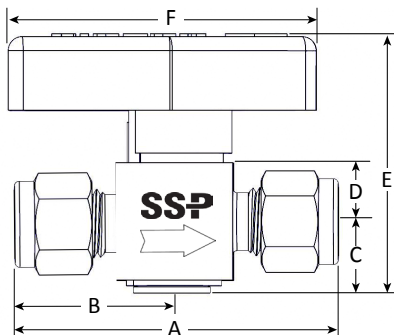

End Connection		Basic Part Number	CV	Dimensions in. (mm) ^{3,4}							
Inlet/Outlet	Size			Orifice	A	B	C	D	E	F	G
Fractional Tube Fitting ¹	1/8 in.	PV4-D2	0.10	0.093 (2.3)	1.99 (50.5)	0.99 (25.1)	0.47 (11.9)	0.38 (9.7)	1.68 (42.7)	2.00 (50.8)	0.75 (19.1)
	1/4 in.	PV4-D4	1.6	0.172 (4.4)	2.17 (55.1)	1.08 (27.4)	0.47 (11.9)	0.38 (9.7)	1.68 (42.7)	2.00 (50.8)	0.75 (19.1)
	3/8 in.	PV4-D6	1.1	0.172 (4.4)	2.29 (58.2)	1.14 (29.0)	0.47 (11.9)	0.38 (9.7)	1.68 (42.7)	2.00 (50.8)	0.75 (19.1)
	3/8 in.	PV6-D6	6.4	0.283 (7.2)	2.66 (67.6)	1.33 (33.8)	0.67 (17.0)	0.56 (14.2)	2.20 (55.9)	2.63 (66.8)	1.12 (28.4)
	1/2 in.	PV6-D8	4.4	0.283 (7.2)	2.88 (73.2)	1.44 (36.6)	0.67 (17.0)	0.56 (14.2)	2.20 (55.9)	2.63 (66.8)	1.12 (28.4)
Duolok Metric Tube Fittings ²	6 mm	PV4-DM6	1.6	0.172 (4.4)	2.17 (55.1)	1.08 (27.4)	0.47 (11.9)	0.38 (9.7)	1.68 (42.7)	2.00 (50.8)	0.75 (19.1)
	8 mm	PV6-DM8	6.4	0.283 (7.2)	2.60 (66.0)	1.30 (33.0)	0.67 (17.0)	0.56 (14.2)	2.20 (55.9)	2.63 (66.8)	1.12 (28.4)
	10 mm	PV6-DM8	6.4	0.283 (7.2)	2.68 (68.1)	1.34 (34.0)	0.67 (17.0)	0.56 (14.2)	2.20 (55.9)	2.63 (66.8)	1.12 (28.4)
	12 mm	PV6-DM12	4.8	0.283 (7.2)	2.88 (73.2)	1.44 (36.6)	0.67 (17.0)	0.56 (14.2)	2.20 (55.9)	2.63 (66.8)	1.12 (28.4)
Female NPT	1/8 in.	PV4-2PF	1.2	0.172 (4.4)	1.78 (45.2)	0.89 (22.6)	0.47 (11.9)	0.38 (9.7)	1.68 (42.7)	2.00 (50.8)	0.75 (19.1)
	1/4 in.	PV4-4PF	0.9	0.172 (4.4)	2.09 (53.1)	1.05 (26.7)	0.47 (11.9)	0.38 (9.7)	1.68 (42.7)	2.00 (50.8)	0.75 (19.1)
	1/4 in.	PV6-4PF	4.3	0.283 (7.2)	2.38 (60.5)	1.19 (30.2)	0.67 (17.0)	0.56 (14.2)	2.20 (55.9)	2.63 (66.8)	1.12 (28.4)
	1/2 in.	PV6-8PF	2.7	0.283 (7.2)	2.88 (73.2)	1.44 (36.6)	0.67 (17.0)	0.56 (14.2)	2.20 (55.9)	2.63 (66.8)	1.12 (28.4)
Male NPT	1/8 in.	PV4-2PM	1.0	0.172 (4.4)	1.53 (38.9)	0.76 (19.3)	0.47 (11.9)	0.38 (9.7)	1.68 (42.7)	2.00 (50.8)	0.75 (19.1)
	1/4 in.	PV4-4PM	1.0	0.172 (4.4)	1.90 (48.3)	0.95 (24.1)	0.47 (11.9)	0.38 (9.7)	1.68 (42.7)	2.00 (50.8)	0.75 (19.1)
	1/2 in.	PV6-8PM	2.4	0.283 (7.2)	2.64 (67.1)	1.32 (33.5)	0.67 (17.0)	0.56 (14.2)	2.20 (55.9)	2.63 (66.8)	1.12 (28.4)
Male NPT to Fractional Tube Fitting	1/4 in.	PV4-4PM-D4	0.9	0.172 (4.4)	2.03 (51.2)	0.95 (24.1)	0.47 (11.9)	0.38 (9.7)	1.68 (42.7)	2.00 (50.8)	0.75 (19.1)
Male to Female NPT	1/4 in.	PV4-4PM-4PF	1.0	0.172 (4.4)	2.00 (50.8)	0.95 (24.1)	0.47 (11.9)	0.38 (9.7)	1.68 (42.7)	2.00 (50.8)	0.75 (19.1)
Female ISO Tapered	1/4 in.	PV4-4FRT	0.9	0.172 (4.4)	2.21 (56.1)	1.11 (28.2)	0.47 (11.9)	0.38 (9.7)	1.68 (42.7)	2.00 (50.8)	0.75 (19.1)
	1/2 in.	PV6-8FRT	2.7	0.283 (7.2)	3.14 (79.8)	1.57 (39.9)	0.67 (17.0)	0.56 (14.2)	2.20 (55.9)	2.63 (66.8)	1.12 (28.4)

¹ The Basic Ordering Numbers for tube fitting end connections specify Duolok end connections. For Unilok and Griplok end connections, see the Tube Fitting End Connection options on page 6.

² Only Duolok tube ends are available in metric sizes.

³ Dimensions are subject to change.

⁴ Dimensions shown with tube fitting nuts finger-tight.

Options & Accessories

Tube Fitting End Connections

SSP provides three tube fitting designs for all PV Series valves. Use the designators below to indicate the required design. For more information about SSP tube fitting end connections see our tube fitting catalogs.

Example: PV4-U4-316 for Unilok tube end connections.

Design	Description	Designator
Duolok	2-Ferrule	D
Unilok	1-Ferrule	U
Griplok	2-Ferrule	G

Body Material

Select the valve body material required and add the designator to the valve basic part number.

Example: PV4-D4-B

Material	Designator
316 Stainless Steel	-316
Brass	-B

O-Ring Material

FKM is the standard O-ring material for all PV Series valves. To specify other O-ring materials add the material designator from the table below to the basic part number.

Example: PV4-D4-316-BN

Material	Designator
Nitrile	-BN
Ethylene Propylene	-EP
Perfluoroelastomer	-KZ
Neoprene	-NE

Handle Colors

Green nylon handles are standard on non-vented valves. Red handles are standard on vented valves. For standard colored handles do not use a color designator. To select a different color handle, add the designator from the table below.

Example: PV4-D4-316-RD

Handle color	Designator
Black	-BK
Blue	-BL
Green	-GR
Red	-RD

Locking Hardware

SSP offers aluminum locking devices all PV Series valves and 316 stainless steel locking devices for PV4 valves only.

PV Series locking devices:

- Meet OSHA Lockout/Tag Out Standard 29 CFR Part 1910.147
- Use padlock with shackle diameters from 1/4 to 5/16 in. (6.4 to 8mm)
- Available factory installed or for field installation



Factory installed locking hardware can be added to any size valve by adding -LD for aluminum and -LDSS stainless steel devices to the part number.

Example: PV6-8PF-316-LD

To order locking hardware kits for field installation, select the part number from the table below. Kits include the locking plate installation instructions and all necessary hardware.



Series	Part Number
Aluminum	
PV4	PV4-LDK
PV6	PV6-LDK
316 SS	
PV4	PV4-LDSSK

Stainless Steel Handles

PV Series valves are available with a stainless steel handle and plug for valves with both brass and stainless steel valve bodies.

To order PV Series Plug Valves with stainless steel handles, add -BH1 to the part number. Example: PV4-D6-316-BH1

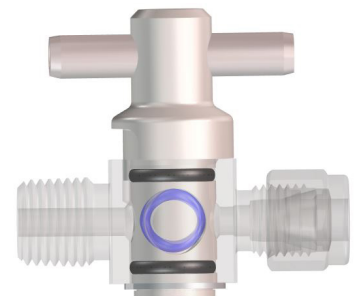

Special Cleaning

ASTM G93, Level C and CGA G-4.1 compliant cleaning is available for valves with oxygen compatible lubricant. To specify special cleaning, add -XP98 to the basic ordering number. Example: PV4-D4-316-XP98

Vented Valves

PV Series plug valves are available with a vented stem and ported body to allow downstream pressure to vent to the atmosphere when the valve is in the closed position.

- Vented PV Series valves come standard with a red handle. See the Handle Colors section on page 6 for other colors
- Note: The pressure rating for vented plug valves is 150 psig (10.3 bar).

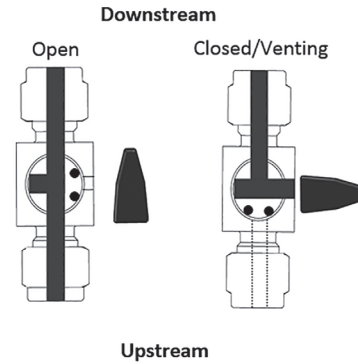

To order PV Series vented plug valves, add a V to the valve size designator in the basic part number.

Examples: PV4V-D4-316

Note: Red handles are standard on vented valves. When specifying vented valves no handle designator is required

Special Orders

The Part Numbers and Dimensions table (page 5) contains only the most popular valve configurations; many more are available. If the required valve configuration is not in the Part Numbers and Dimensions tables, use the chart below to build part numbers for quotation purposes.

A **B** **C** **D** **E** **F**
PV4 V -4PM -D4 - 316 - GR- LD

A Orifice/Valve Size
 0.172 PV4
 0.283 PV6

B Vented Valves
 No Vent Blank
 Downstream Vent V

E Body Material
 316 SS -316
 Brass -B

C Inlet **D Outlet¹**

Types		Fractional Sizes	
Duolok Tube Fitting	D	1	1/16 in
Unilok Tube Fitting	U	2	1/8 in
Griplok Tube Fitting	G	4	1/4 in
Duolok Metric	DM	6	3/8 in
Female NPT	PF	8	1/2 in
Male NPT	PM	Metric Sizes	
Male ISO Tapered	MRT	6	6 mm
Female ISO Tapered	FRT	8	8 mm
		10	10 mm
		12	12 mm

F Options²

O-rings	Handles
Fluorocarbon FKM (Standard) -Blank	Green Nylon ³ Blank
Nitrile Rubber -BN	Black Nylon -BK
Ethylene Propylene -EP	Blue Nylon -BL
Perfluoroelastomer -KZ	Red Nylon ³ -RD
Neonrene -NE	SS plug with T-bar handle -BH1
Other Options	
Locking Device Aluminum -LD	
Locking Device Stainless Steel -LDSS	
Clean per ASTM G93 Level C and CGA G-4.1 XP98	

¹Tube fitting end connection part numbers are formatted Type followed by Size. Example: D6

Pipe ends are formatted Size followed by Type. Example: 6PF. If the inlet and outlet are the same use only one designator

²Options are added to the end of the part number in alphabetical order. Example: PV6-D4-316-BL-EP

³Green handles are standard on all non-vented valves. Red handles are standard on vented valves. When specifying vented valves no handle designator is required.

⚠ Important Information

IMPROPER SELECTION OR IMPROPER USE OF THE PRODUCTS DESCRIBED HEREIN OR RELATED ITEMS CAN CAUSE PERSONAL INJURY AND PROPERTY DAMAGE. It is the sole responsibility of the system designers and users to properly select and use products for their specific applications. This document has been provided to users with technical expertise as a reference for further investigation to determine specific product needs relative to their design requirements.

Testing

All PV Series valves are factory tested with Nitrogen to 1000 psig (69 bar) at 70°F (20°C).

Warranty

FloLok valves are backed by the SSP Limited Life Time Warranty. This warranty is available from your local distributor or at www.mySSPusa.com.

SSP

Founded 1926

Privately owned, third generation business

Modern single-site vertically integrated manufacturing facility

DFARS-compliant raw material

ISO 9001 quality management system

Lifetime Limited Warranty



*The Only
100% American Made
Instrument Valves & Fittings*

8250 Boyle Parkway • Twinsburg, OH 44087
330-425-4250 • www.mySSPusa.com

©2018 SSP Fittings Corp. All rights reserved.

PVPC-010-18A